

LAMINATE INSTALLATION GUIDELINES

⚠ WARNING Drilling, sawing, sanding or machining wood products can expose you to wood dust, a substance known to the State of California to cause cancer. Avoid inhaling wood dust or use a dust mask or other safeguards for personal protection. For more information go to www.P65Warnings.ca.gov/wood.

For successful installation, remember:

1. No acclimation required when installation site conditions are climate controlled before and during installation.
2. Identify the tongue side and the groove side. The tongue side (the smaller extension without a ridge on it) goes against the beginning wall.
3. Install vapor barrier if subfloor is cement (6 mil polyethylene film).
4. Always use an underlayment padding above the vapor barrier and below the laminate flooring planks. If pad is pre-attached, no additional underlayment should be used.
5. Install parallel to the main light source.
6. Before cutting, plan your installation so each plank is at least 12" long and that the first and last rows are at least 2.5" wide.
7. No transition strip is required when the length or width of installed planks measures less than 40', or in doorways unless plank direction changes.

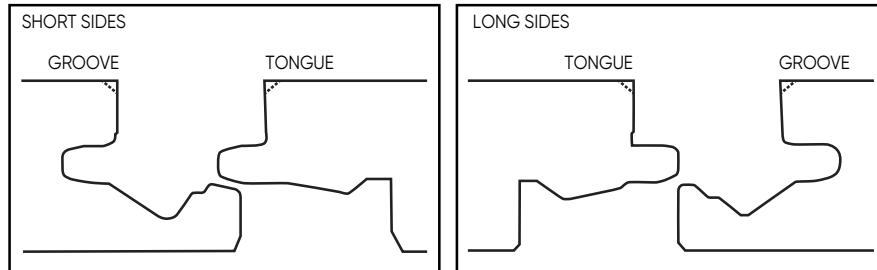

Tools and supplies required:

Foam underlayment for laminate floors • Spacers (min 5/16" - max 3/8" • Saw • Adhesive tape • Minimum 6 mil poly vapor barrier (plastic sheeting) for crawl space and concrete floor installations • Rubber mallet • Ruler • Pencil • Tape measure • Utility knife • Pull bar • Tapping block • Flexible 100% silicone sealant • Felt protectors • NIOSH mask • Gloves • Safety Glasses

Installing underlayment

After thoroughly cleaning the subfloor, you should install a laminate floor foam underlayment. Run the foam underlayment in the same direction as the flooring planks. The underlayment should be butted side-by-side with no overlap. Tape seams together. If you are installing over a concrete subfloor, a 6-mil poly (plastic sheeting) is to be installed under the laminate floor foam underlayment. (Many foam underlayments already have this plastic sheeting pre-attached).

IMPORTANT PRE-INSTALLATION INFORMATION

Make sure subfloor is clean, dry and flat (maximum 3/16" deflection over 10'.) Always use safety glasses and a mask. Visit our website for more help.

Suitable subfloors for Laminate Flooring are:

- Existing floor surfaces including hardwood floors, linoleum, resilient vinyl, PVC (plastic floor surfaces must be permanently attached to the subfloor).
- Cement floors on all grades/elevations (maximum residual moisture 2.0 CM%). With a calcium chloride test, the maximum acceptable reading is 5.0 lbs/24 hours/1000 sq. ft.
- Anhydrite and Anhydrite tiles, Magnesium Cement (max residual moisture 0.3 CM%)
- Wood subfloor moisture 14.5% maximum
- Concrete relative humidity 70% maximum

Attention!

Without a documented measurement of residual moisture content, a claim against the manufacturer for damages cannot be considered. Concrete sub-floors must always be covered with a 6 mil vapor barrier even if linoleum, PVC or resilient vinyl is firmly attached to the concrete.

Installation instructions

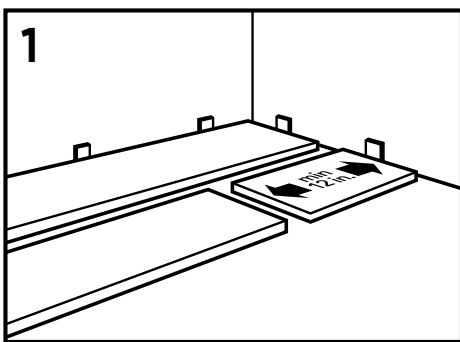

Before cutting, select your beginning wall and plan your installation. Lay planks tongue side facing the wall for the first 2 rows on the floor close to the wall. Each plank should be at least 12" long.

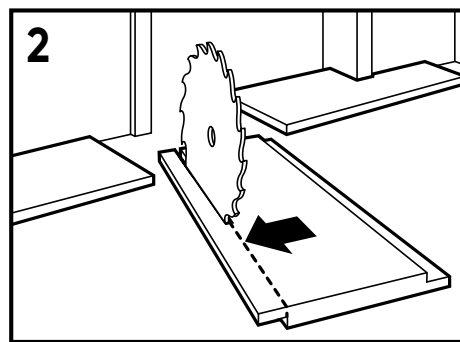

Remove the tongue side (see Figure 1 below) on only the planks in the first row that face the wall to allow room for spacers.

Figure 1

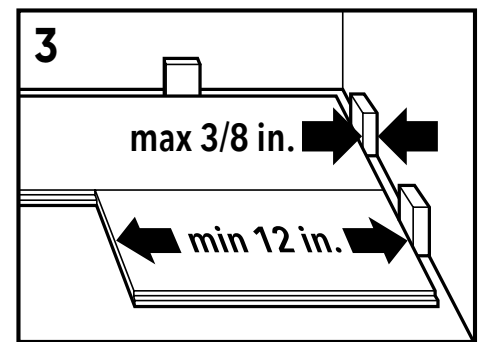
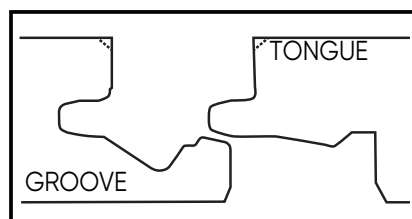

Always allow for 5/16" min to 3/8" max expansion at walls and around fixed objects.

A transition strip is required when length or width of installed planks measures 40' and in doorways if plank direction changes.

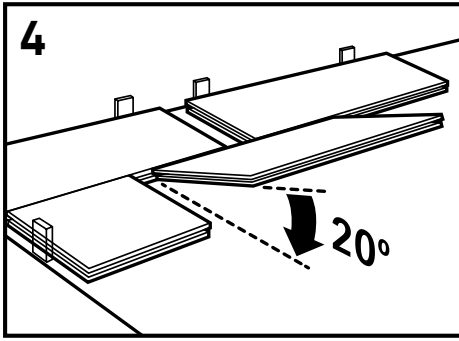

Lock in panel lengthwise. Allow a 12" minimum end-joint stagger row to row. Install first and second row at the same time to help ensure end-joints are perfectly square.

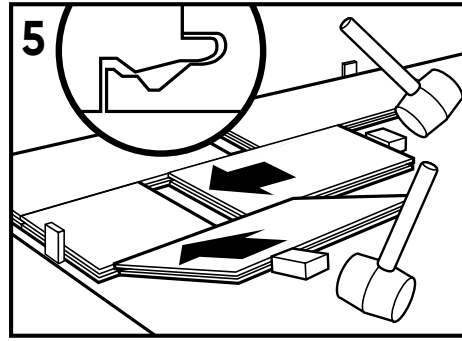

Use a 4"-6" piece at an angle to hold the tongue and the groove on the same plane, limit end-joint damage and ensure planks engage square. Tap end-joints with multiple taps, striking the tapping block evenly until end-joints close. **NOTE: Tapping too hard or striking the tapping block unevenly can result in installation-related damage or peaking.**

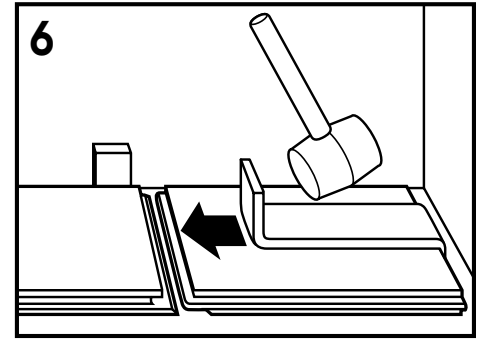

Fit the last panel in the row using a pull bar.

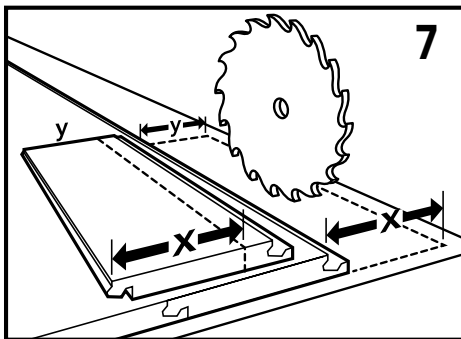

Repeat steps 4 through 6 until you reach the last row. Cut last row to size (2-1/2" minimum width).

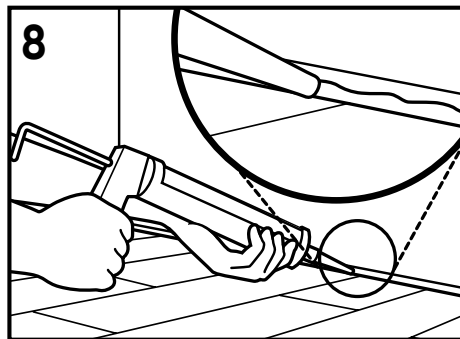

After installing planks and before installing trim, remove all spacers. Create a water tight seal by applying flexible 100% silicone sealant along the entire perimeter of room and around fixed objects. Do not use acrylic sealant. To limit the amount of sealant to be used, first fill all expansion spaces with 3/8" compressible PE foam backer rod and cover with silicone sealant.

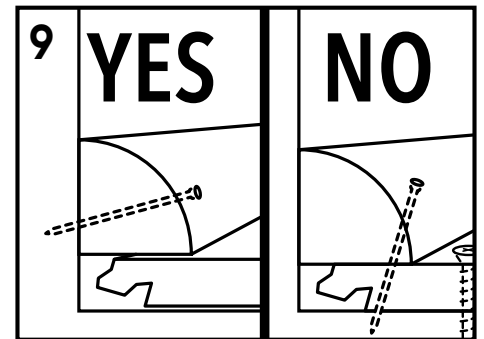

Prior to installing moldings, apply silicone sealant to the portion of the molding or transition that will rest on the laminate flooring surface. Install moldings and immediately wipe away excess sealant. Apply silicone sealant at connections to doorframes and other fixed objects. Ensure floor is able to "float". Do not nail planks or trim to floor.

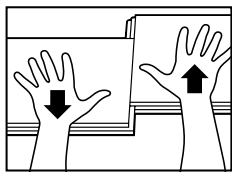

DISASSEMBLING: Disengage entire row by lifting up row delicately at an angle. To separate individual planks, leave them on the ground and then carefully slide the planks apart as illustrated.

Installation under doorway frames:

1. Slide plank under pre-cut door frame.
2. Tap the long side joint closed.
3. Tap the end joint closed.

WORKING WITH LIMITED CLEARANCE

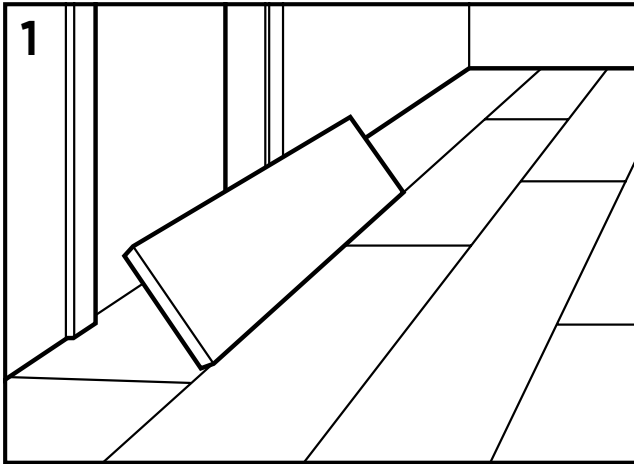

Some long edge joints cannot be installed using a 20° angle.

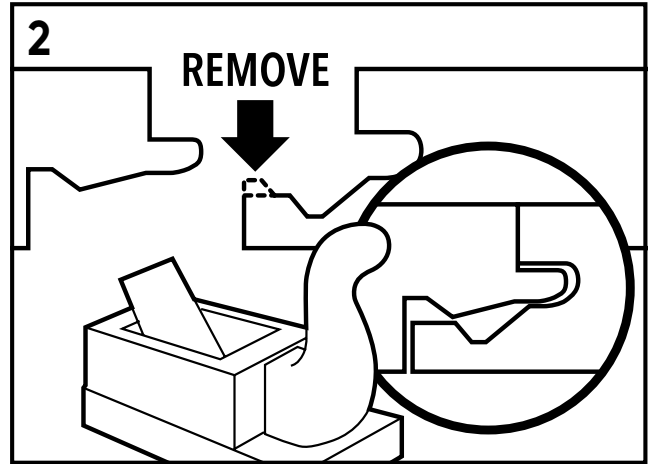

Remove top part of the groove profile.

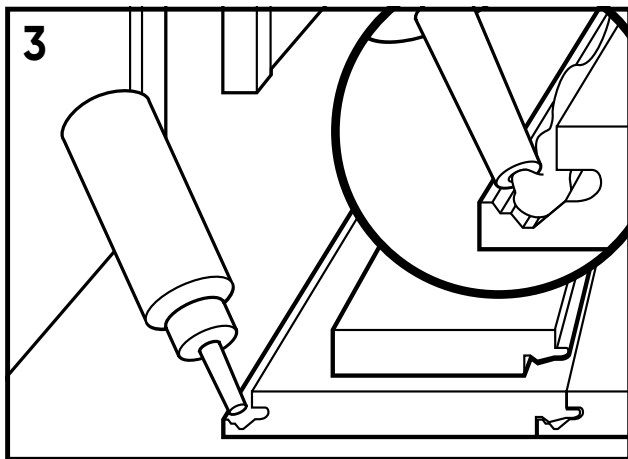

Use good quality wood glue to make the connection.

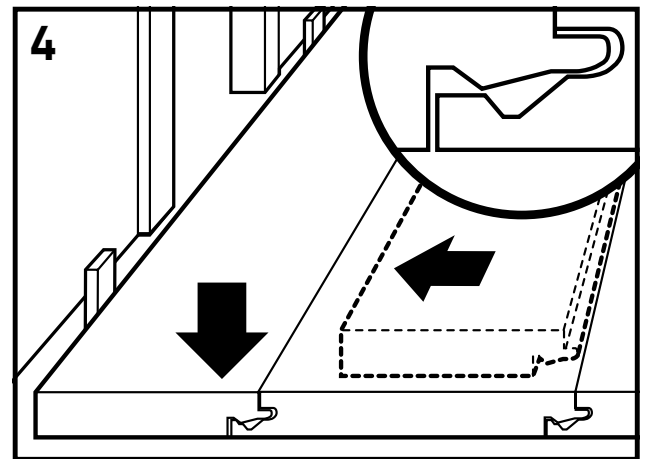

Slide panel into space horizontally and slot into profile. Use these modified planks under doorframes, radiators, cabinet fronts, etc. Use the pull bar to slide the planks where needed.

For questions please call:

(800) 245-0652 or visit www.naturallyagedflooring.com